

Soffit Protection Detail

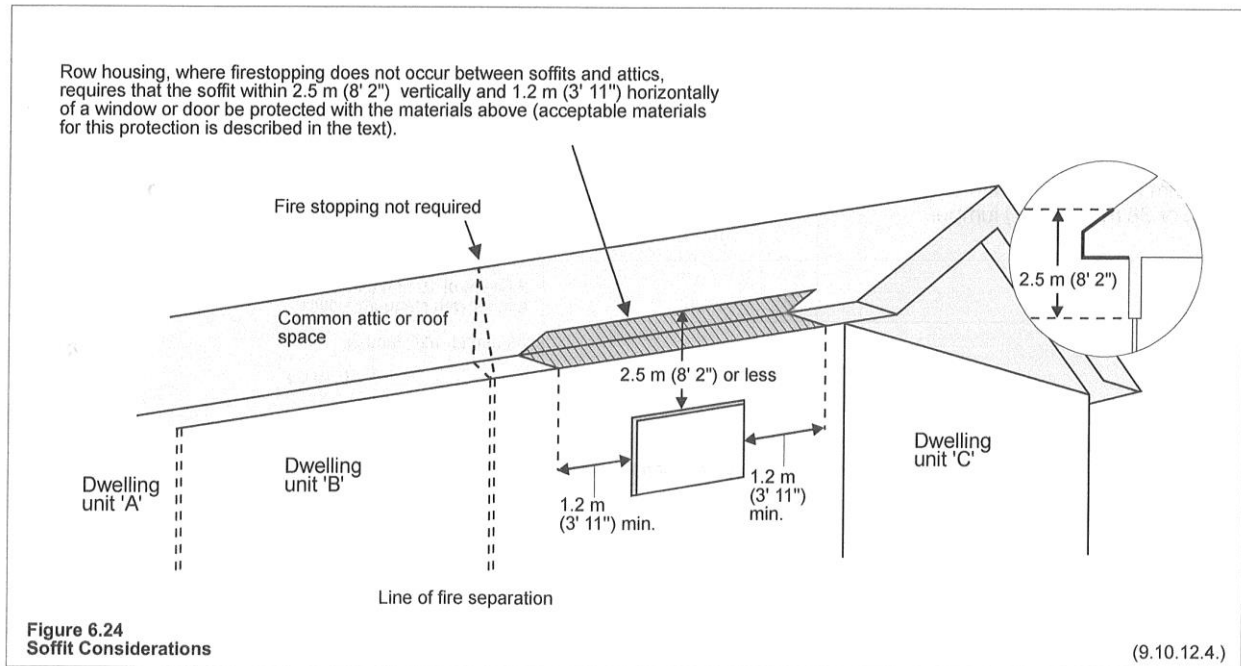

Per Section 9.10.12.4 of the National Building Code, to minimize the potential that fire will travel into an attic and across to another dwelling unit or across a fire separation as shown above, where an attic space spans more than 2 dwellings the soffits must be protected above any door or window where sprinklers or attic fire blocking are not provided.

Examples of acceptable protection are ½" thick Gypsum Board, 3/8" thick Plywood and ½" thick OSB.